

PRECISION TOOLS & COMPONENTS



PLOT NO. H1-830, KHUSHKHERA, BHIWADI ALWAR RAJ, 301707

VISION, MISSION, VALUES AND PURPOSE

OUR VISION

Create a trustworthy relationship with The Customer we serve

OUR MISSION

*Use our pioneering spirit to responsibly
Provide Gauge Fix. & Fabrication Solutions.*

OUR VALUES

*Thrust based on accountability
Excellence in execution
Spirit to lead the way*

OUR PURPOSE

*To Improve the Quality of life the
Communities we serve.*

QUALITY POLICY

We are Committed to customer satisfaction by supply of Gauge ,Fix. & Tools at its competitive cost by continual improvement in our Quality Management system with the involvement of our employees.

QUALITY OBJECTIVES

- To reduce internal rejection with the help of 5's and kaizen methods.
- To enhance customer satisfaction level according to customer parameter's
- On time delivery.
- Quality is our Business.

COMPANY HISTORY

ODISON ENGG. WORKS. (BHIWADI, RAJASTHAN)

- 2003 - ODISON ENGG. WORKS WAS ESTABLISHED IN BHIWADI RAJASTHAN
- 2004 - FABRICATION WORK STARTS FOR INDIAN RAILWAY (NORTH DIVISION)
- 2005 - TOOL MAKING STARTS FOR OMAXE DHARUHERA (HERO GROUP)
- 2009 - TOOL MAKING STARTS FOR BESTEX TAPUKARA (HONDA GROUP)
- 2010 - ADDED HMSI TO ESTEEMED CUSTOMER LIST.
- 2011 - ADDED GTEKT & JTEKT TO ESTEEMED CUSTOMER LIST
- 2016 - ADDED INDO & GOSHI TO ESTEEMED CUSTOMER LIST

PRECISION TOOLS & COMPONENTS (TAPUKARA, RAJASTHAN)

- 2011 -A SUBSIDIARY COMPANY OF ODISON ENGG. WORKS WAS ESTABLISHED IN TAPUKARA (RAJASTHAN).
- 2016 - SUCCESSFULLY STARTED OF MASS PRODUCTION FOR BADVE ENGG.(T1 HMSI)
- 2019- ADDED HONDA CAR TO ESTEEMED CUSTOMER LIST.
- 2019- SUCCESSFULLY DEVELOPED THE 2TG PARTS FOR BESTEXMM .

ACCURATE ENGG. SOLUTION (MANESAR, HARYANA)

- 2017 - A SUBSIDIARY COMPANY OF ODISON ENGG. WORKS IS ESTABLISHED IN MANESAR (HARYANA).

LOCATION

- 2KM FROM HONDA CAR INDIA LTD. (TAPUKARA)
- COVERED AREA 500 SQ.MTR

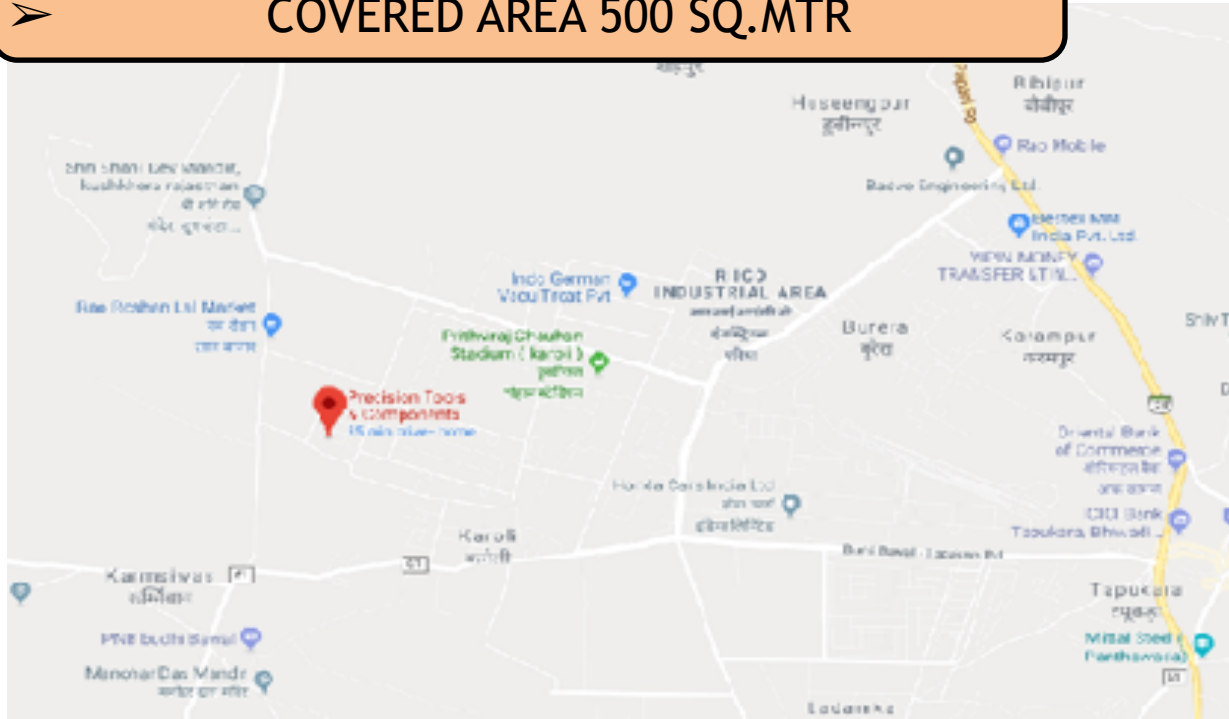

COMPANY VIEW



BHIWADI



KHUSKHERA



MANESAR

MACHINE SHOP

SPOT WELD M/C	:	01	Nos
ARC WELD M/C	:	01	Nos
MIG WELD M/C	:	02	Nos
PIPE CUTTER M/C	:	01	Nos
PRESS M/C(50 TON)	:	02	Nos
BENDING MACHINE	:	02	Nos
BULGE MACHINE	:	01	Nos

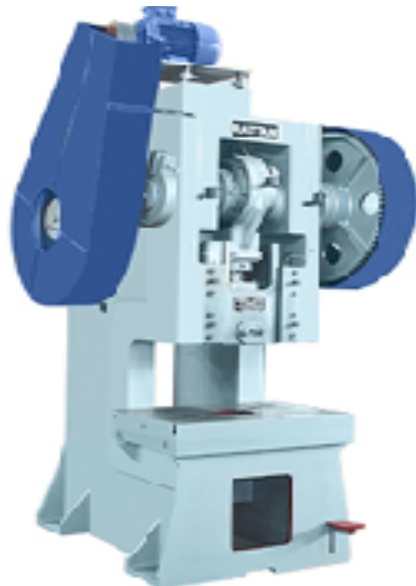

TOOL ROOM

LATHE MACHINE	:	05 Nos
SURFACE GRINDER	:	05 Nos
MILLING MNTR DRO	:	04 Nos
VMC	:	01 Nos
DRILL M/C	:	02 Nos
CYLINDRICAL M/C	:	01 Nos



QUALITY INSTRUMENT

CMM (FARO) 1.5m	: 01 Nos
SURFACE PLATE	: 03 Nos
HEIGHT GAUGE	: 03 Nos
VERNIER DIGITAL	: 06 Nos
DIAL VERNIER	: 10 Nos
MICROMETER	: 06 Nos
DIAL GAUGE	: 06 Nos
BORE GAUGE	: 07 Nos
GAUGE BLOCK SET	: 01 Nos
MAGNET V BLOCK	: 06 Nos
ANGLE PLATE	: 03 Nos



MACHINE SHOP



DESIGN & DEVELOPMENT

DESIGNING TEAM

2 SENIOR DESIGNERS
2 DESIGNERS
3 JUNIOR DESIGNERS

PRODUCT RANGE:-

1. GAUGES
2. WELDING FIXTURES
3. SPECIAL PURPOSE MACHINES
4. TOOLS AND DIES
5. ROBOTIC CELL FOR MIG WELDING
6. LEAK TESTING FIXTURES & MACHINES

PRESS SHOP (COMPONENTS)

PROJECT- 2TG



TUBULAR PARTS

PROJECT – 2TG



PRODUCT OVERVIEW

- GAUGE
- JIG
- ROBOCELL

- FIXTURES
- MACHINES
- TOOLS

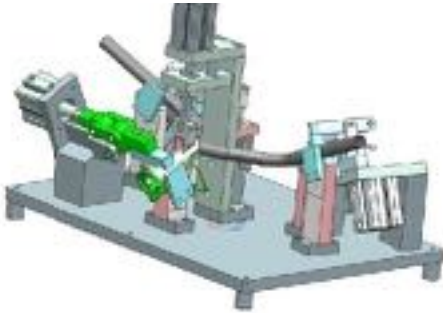

STAY WELDING FIXTURE HANDLE KZK

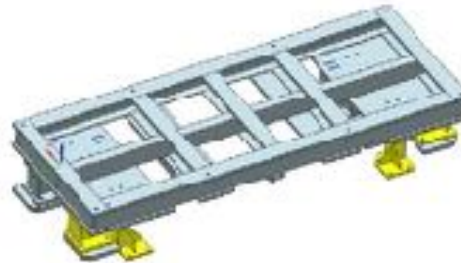

FIXTURE BASE G-TIP



STEP PILLION WELDING FIXTURE LH

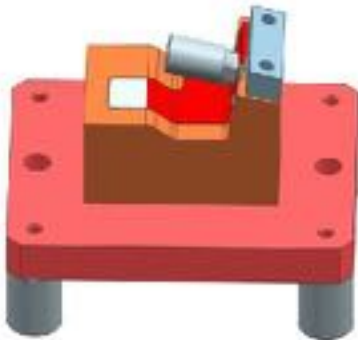

STAY RELAY FR COVER RECEIVING GAUGE

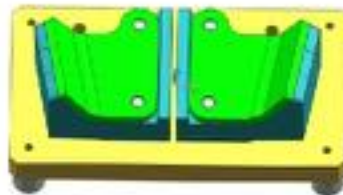

STAY LR FR REAR GRIP INSPECTION GAUGE

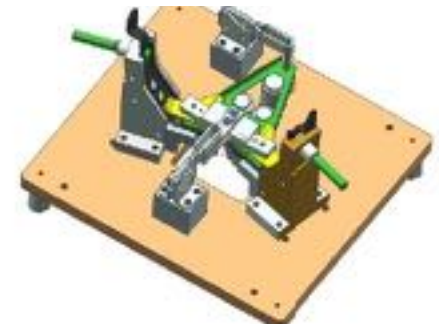

STAY FR FENDER WELDING FIXTURE

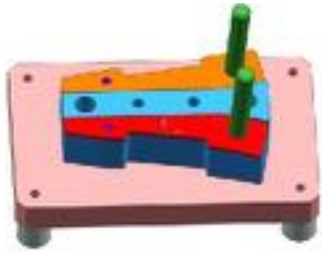

SIDE PATCH LR RECEIVING GAUGE REAR GRIP

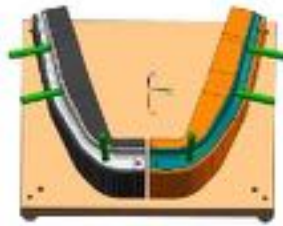
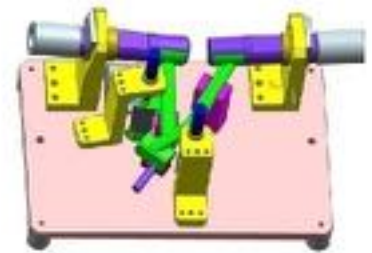
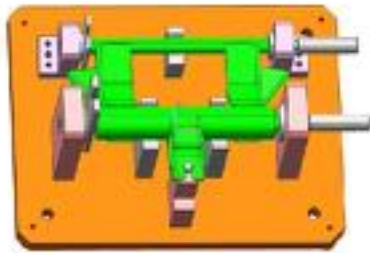

PLATE LR RECEIVING GAUGE REAR GRIP



PILLION RH RECEIVING GAUGE



LINK ENGINE HANGER RECEIVING GAUGE

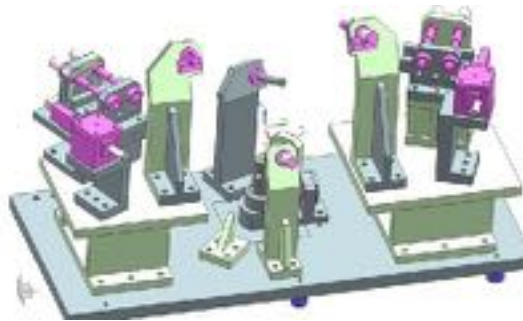

HANDLE KZK RECEIVING GAUGE



2WF AS SIDE PIERCING DIE

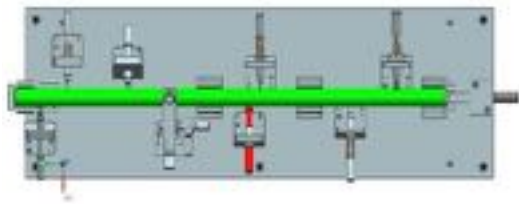

2WF AS SIDE RECEIVING GAUGE

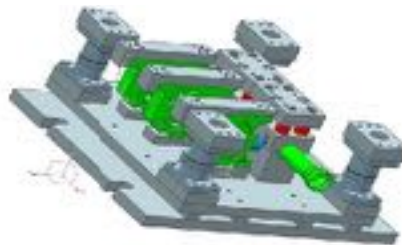

2WF DR SIDE PIERCING DIE



EIPL S7 RG 19426 RECEIVING GAUGE

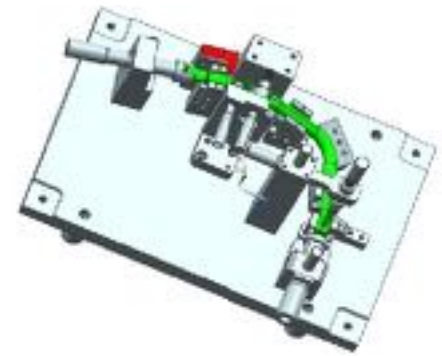
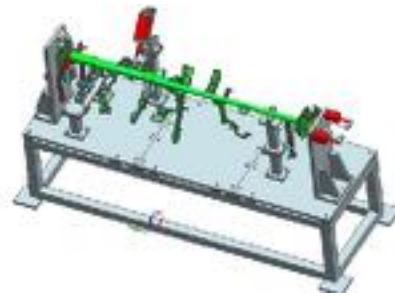
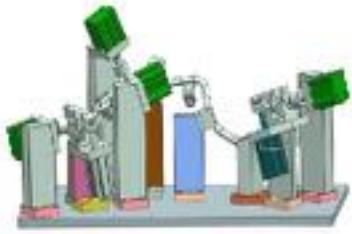

EIPL S7 RG 19426 LEAK TESTING FIXTURE 2WF STEERING BEAM HANGER PART EXISTENCE FIXTURE

2MD 19425 RECEIVING GAUGE

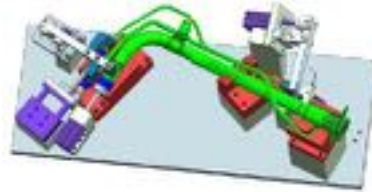
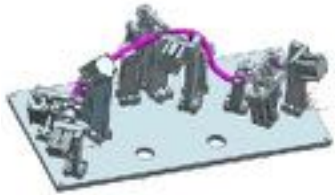

2MD 19426 LEAK TESTING FIXTURE YAD EXPORT NECK MARUTI LEAK TESTING FIXTURE



B6 JBL MARUTI LEAK TESTING FIXTURE

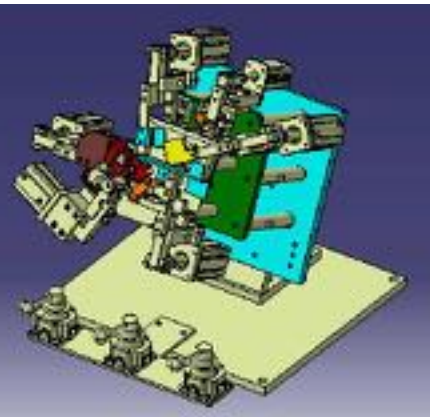

2WF SUB COMP WELDING FIXTURE

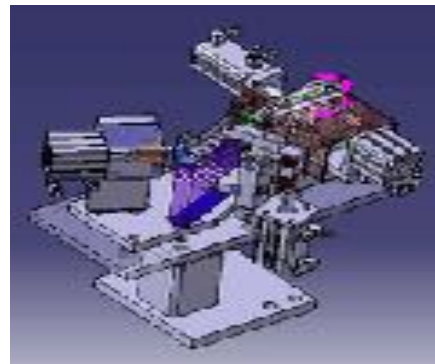

2WF SUB COMP WELDING FIXTURE

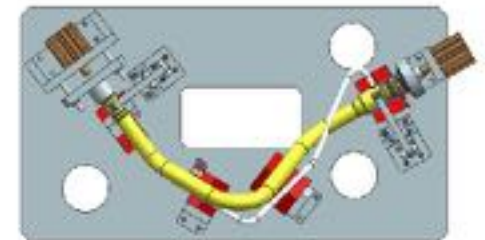

MARUTI LEAK TESTING FIXTURE

2TG PROJECT



MARKING FIXTURE FOR FUEL FILLER PIPE

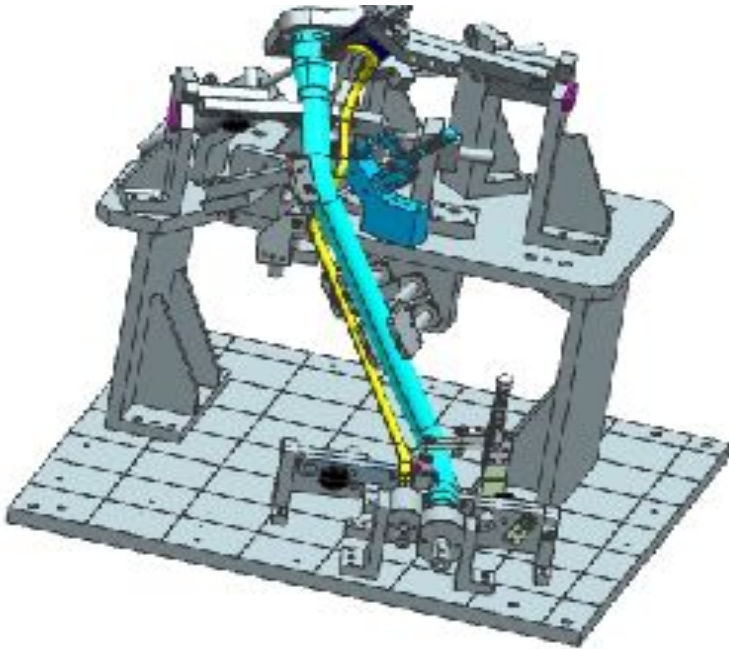

FUEL FILLER ASSY GAUGE

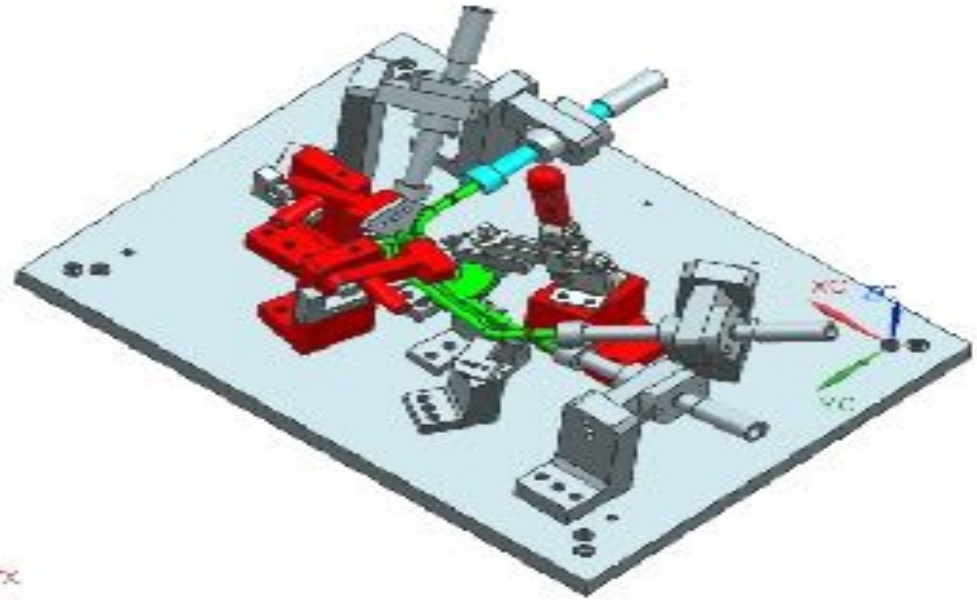

19538 ASSY GAUGE

2TG PROJECT

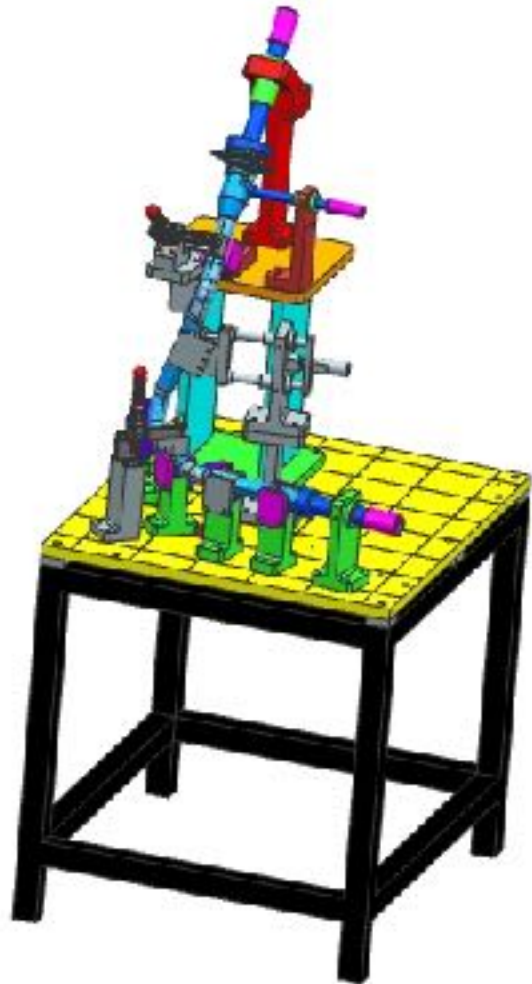

MAIN PIPE BENDING
GAUGE

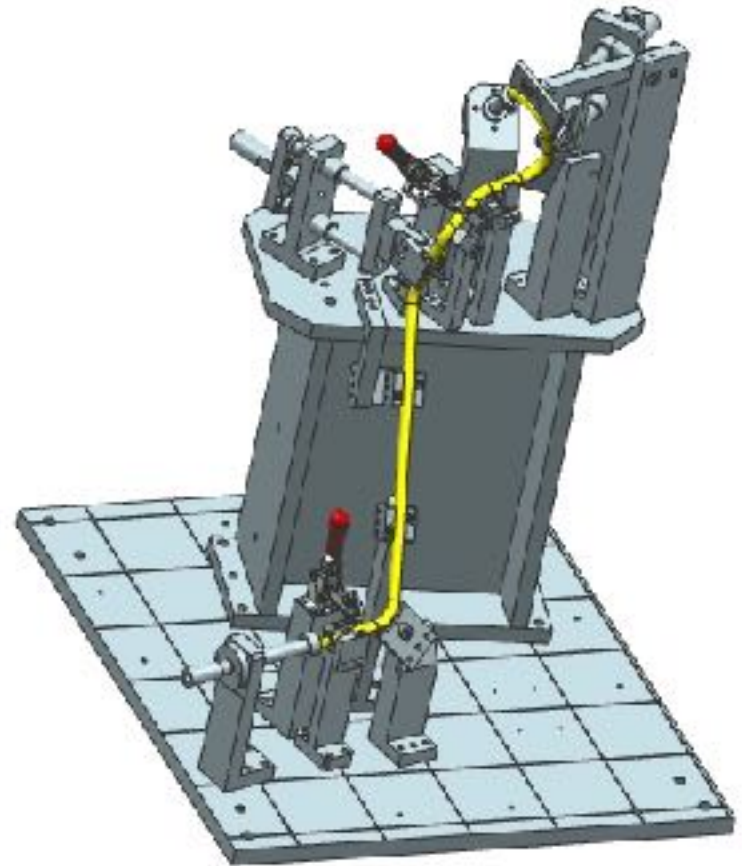

BREATHER PIPE
BENDING GAUGE

2TG PROJECT

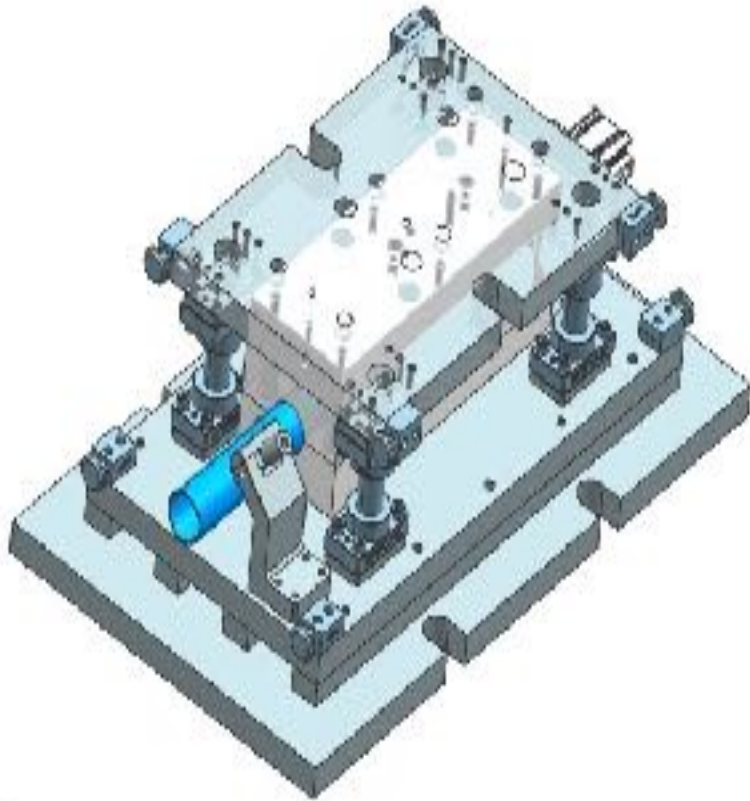

FORMING DIE

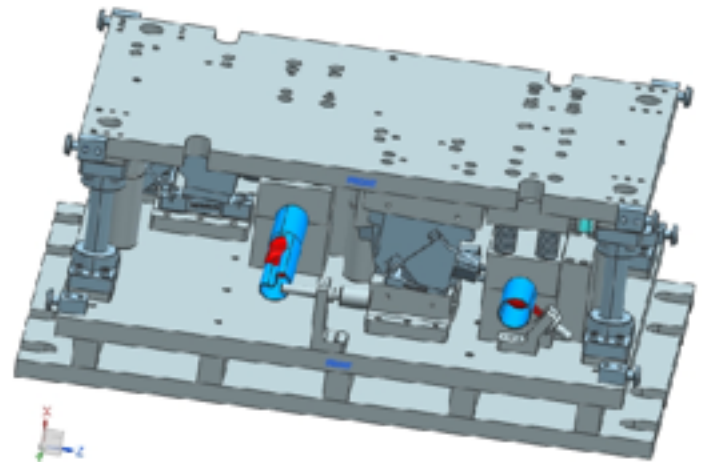

CAM PIERCE DIE

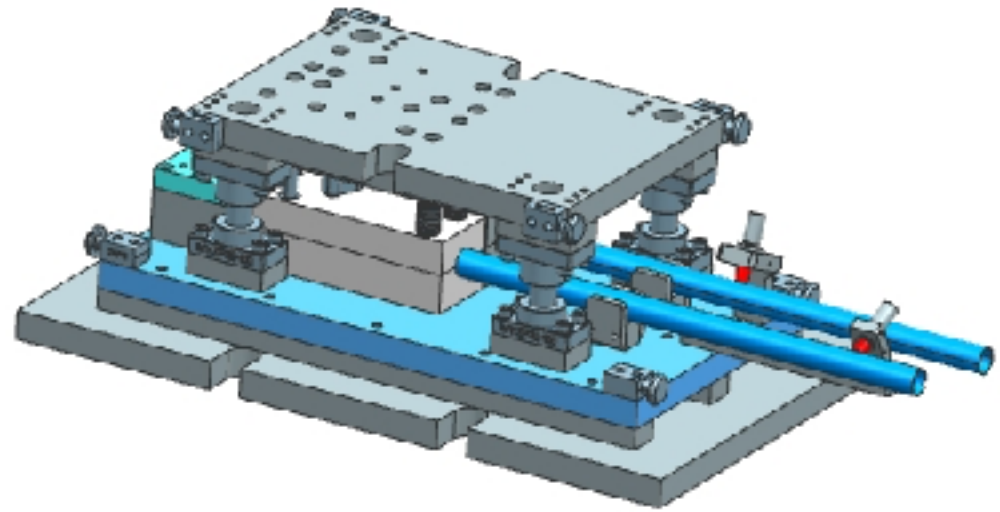

NOTCHING TOOL

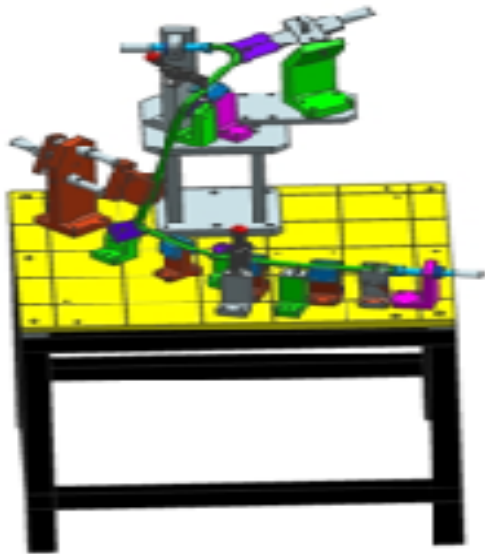

BREATHER PIPE
BENDING GAUGE

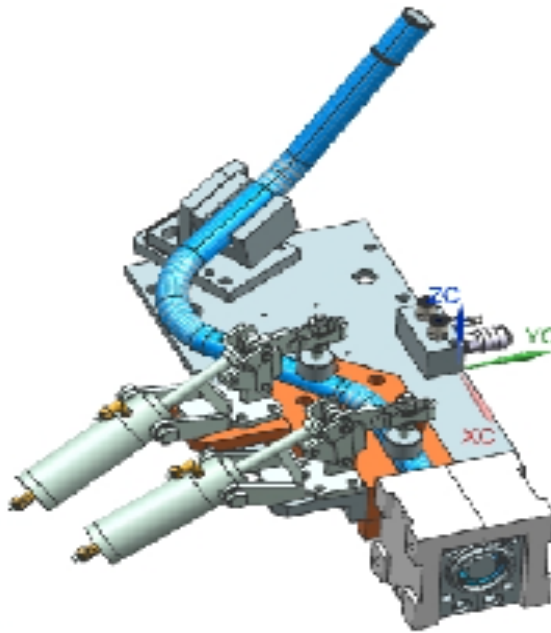

CUTTING JIG

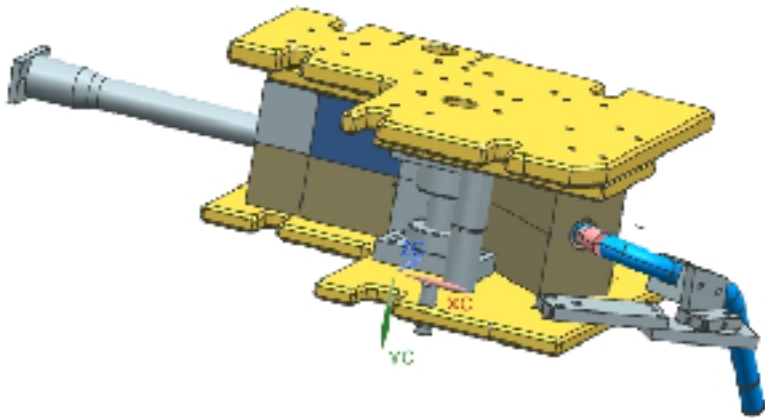

FLARING DIE

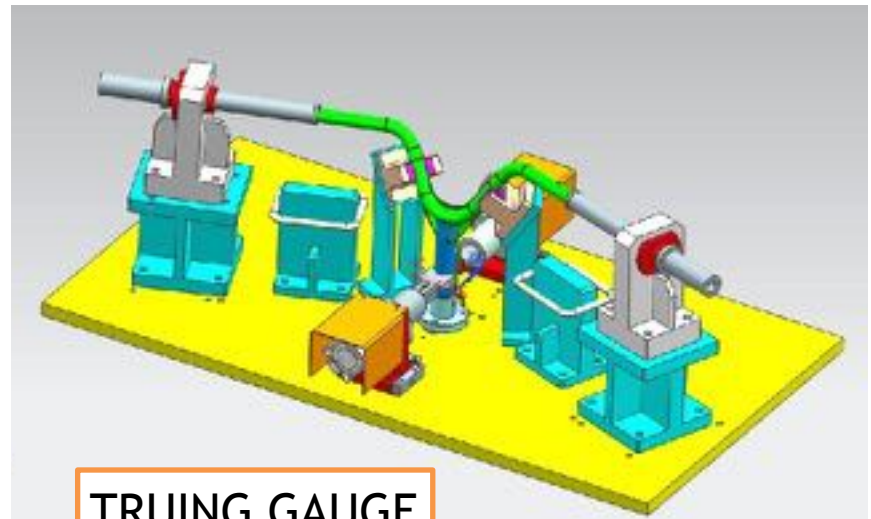

TRUING GAUGE



Y1K MAIN PIPE FUEL FILLER GAUGE

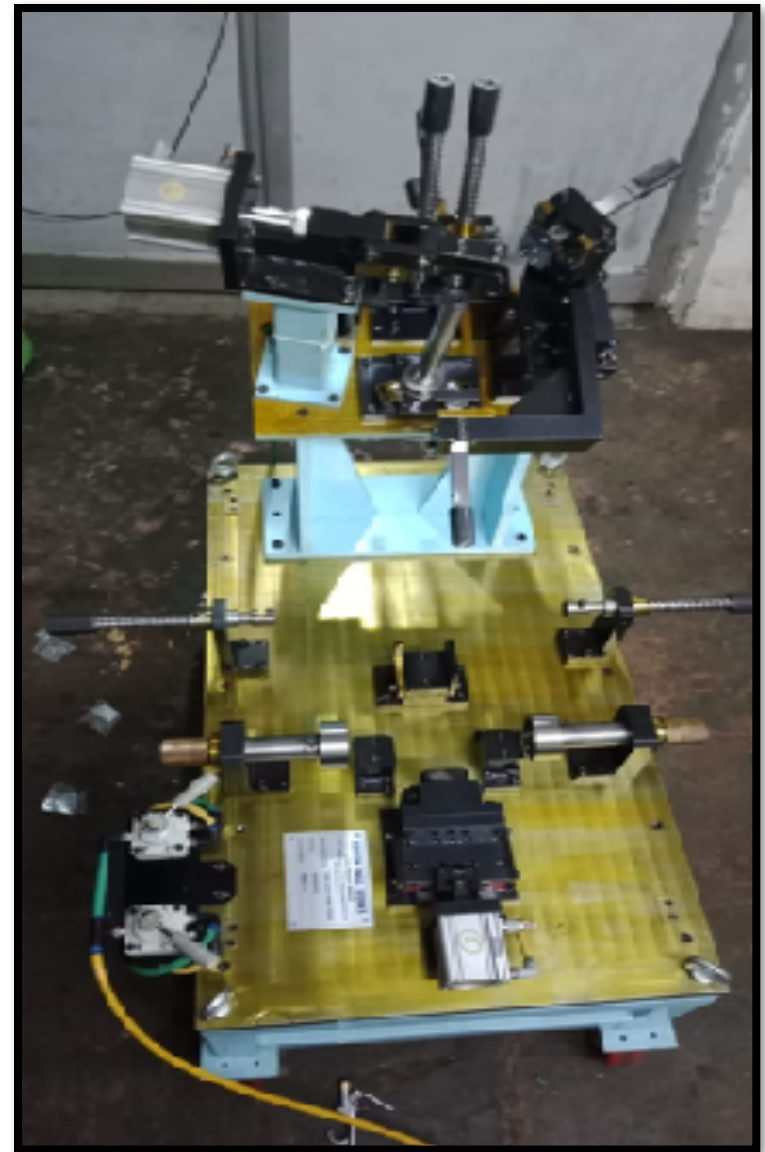

KWP/K24 FRAME CHECKING GAUGE

BULGE MACHINE





OIL COMP FLARE MACHINE

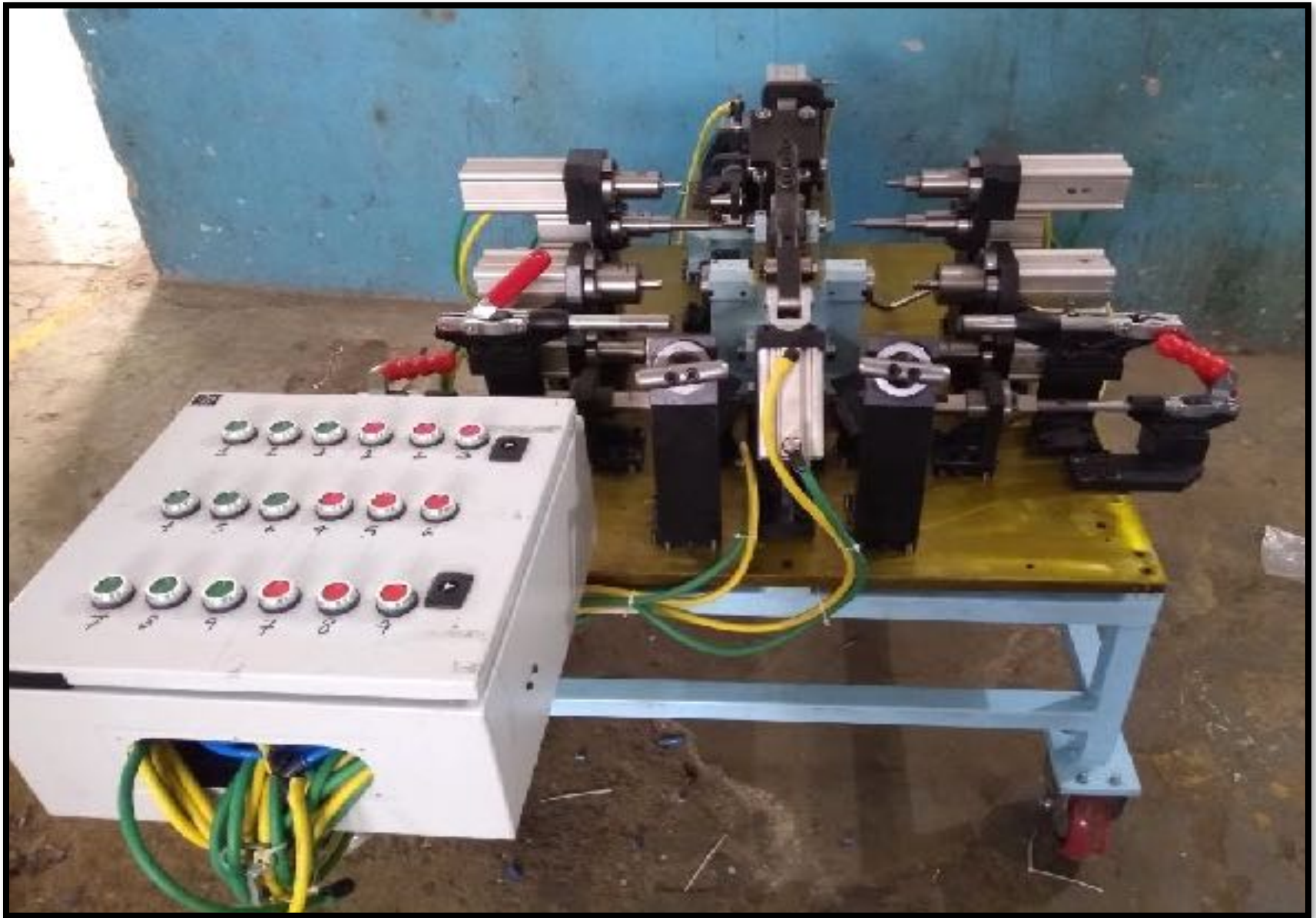

PIVOT BOX WELDING FIXTURE- KYJR



KOLA HANDLE LINE



KOLA HANDLE LINE



SWING ARM (K55) TRUING CUM GAUGE 30



NOTCHING M/C FOR INDO AUTOTECH



MIG WELDING ROBOTIC CELL FOR INDO AUTOTECH

GLOBAL ACHIEVEMENTS

1. Design & Manufacturing of Fuel Filler Pipe Line for Bestex Japan.
2. Design & Manufacturing of Fuel Filler Pipe Toolings for Bestex Thailand.
3. Design & Manufacturing of K-23/K-55 Front Frame line for Honda Motorcycle Bangladesh.



VALUABLE CUSTOMERS



HONDA



HT

Honda Trading



Badve Group



JTEKT



SANKEI

Sankei Giken India Pvt. Ltd.



hanon
SYSTEMS

BESTEX



THANK YOU
LOOKING FORWARD TO LONG TERM RELATIONSHIP



precision1954@gmail.com

Mob. No.-09785507607,09518126730